

UTA - Residential Elevators with Accordion Gates

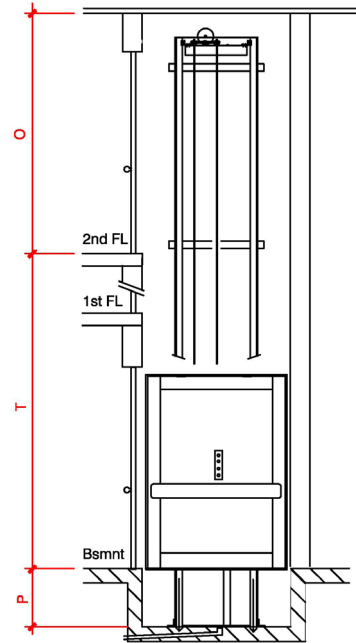
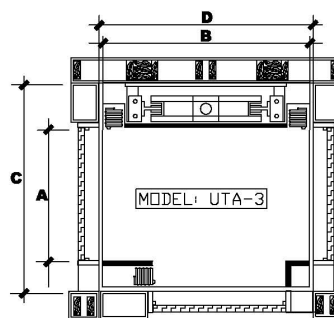
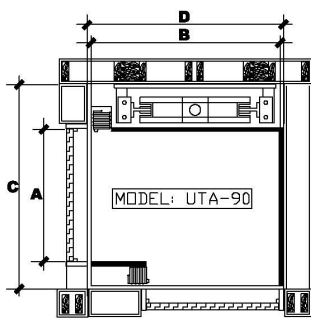
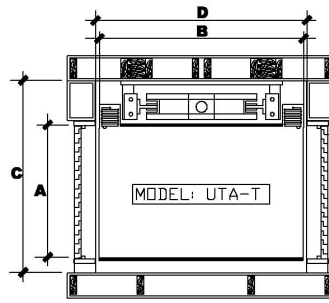
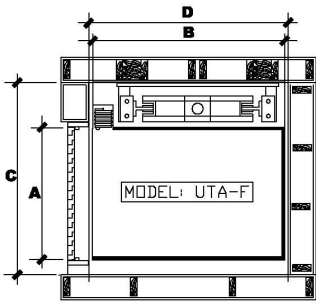

Minimum Dimensions:

Model	A	B	C	D
UTA-F	36"	48"	50"	50"
UTA-T	36"	54"	50"	56"
UTA-90	36"	48"	56"	50"
UTA-3	36"	54"	56"	56"

- P - Pit Depth 6" (150 mm), Minimum
- T - Travel 50' (15 240 mm), Maximum
- O - Overhead 8' (2440 mm), Minimum

Standard Technical Information:

Drive System: MRL Gearless or 1:2 Roped Hydraulic

Power: 220 VAC/60 Hz/1 Phase or 208 VAC/60 Hz/3 Phase

Speed: 0.15 m/s to 0.20 m/s

Capacity: 340 kg to 450 kg allowing for 3 - 5 Persons

Machine Room: Not required for MRL Gearless option, can be up to 12 m away from shaft for Hydraulic

Car:

- Cab size minimum of 3'x 4' x 6'8"
- and interior selected by owner from UT options
- Manual or automatic Accordion style car gates
- Safety light curtain optional

Hoistway Door: 3' X 6' 8" Solid wing door provided by others

- *Notes - UT is able to provide custom design options specific to each project
- Dimensions are subject to modification without notification